

**Tungaloy**

Member IMC Group

Keeping the Customer First

Tungaloy Report No. 391-E

**TURNLINE**

New grooving and parting off tools

**TUNG**CUT



**The complete grooving solution !**



# Multifunctional system diverse grooving ne

## Features

● Suited to a wide variety of grooving operations

### ■ Multi-functional grooving system

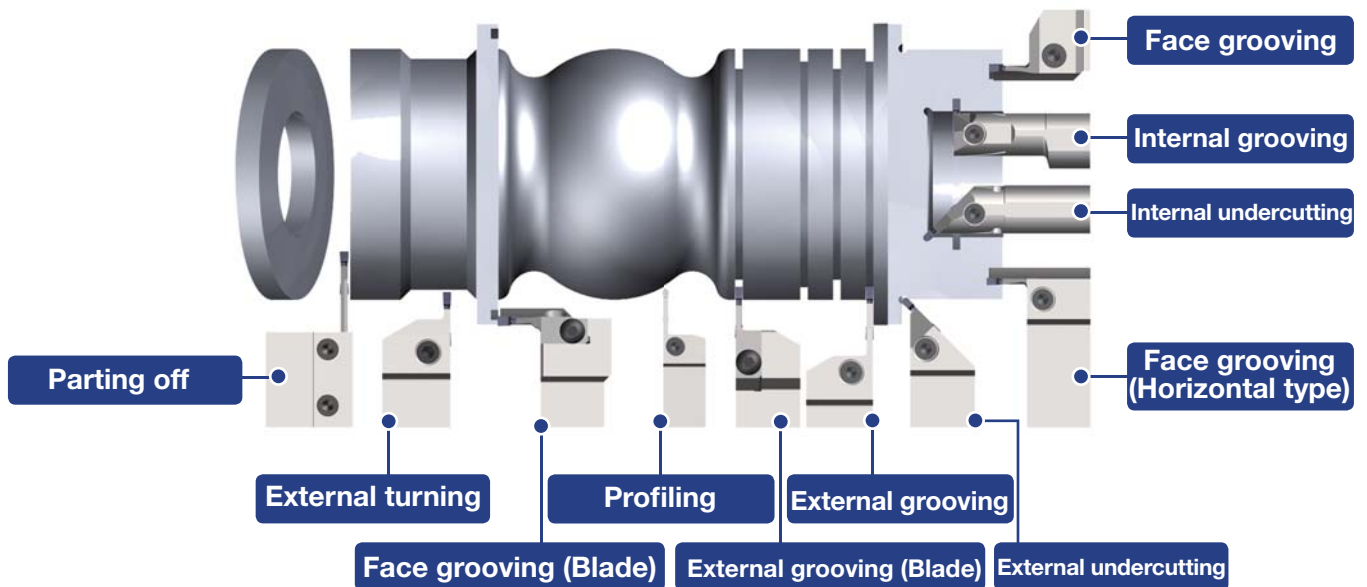

● High clamping rigidity

*For stable tool life and accuracy*

### ■ Clamping system

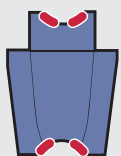

● Stable and safe contact points !

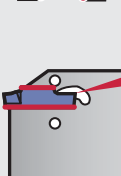

High repeatability and durability due to long pocket !

### ■ Limited cutting edge displacement

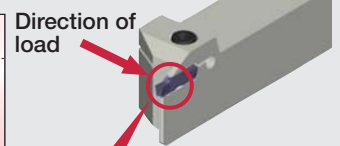
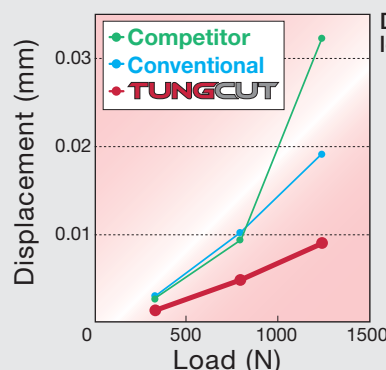

Measuring point

# em for eds!



## ● Great selection of standard items

*HOLDERS AND INSERTS APPLICABLE FOR ALL GROOVING DEMANDS !*

### ■ Comparison of items

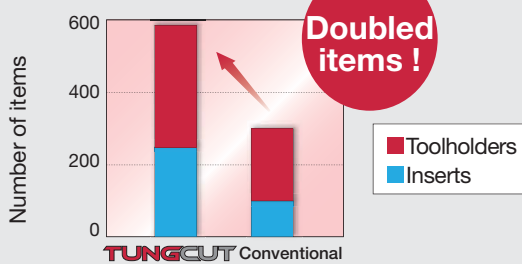

### ■ Line-up of width in TungCut

type	Application	TUNG CUT (mm)	Conventional (mm)
CTE	External grooving	2 - 8	2 - 5
CTI	Internal grooving	3 - 8	3 - 5
CTF	Face grooving	3 - 6	3 - 5
JCTE	Small lathe tools	1.4 - 3	2
CGP	Parting off (Blade type)	1.4 - 8	3 - 5
CGE	Parting off (Shank type)	3 - 6	2 - 5

### Mono block toolholders

High rigidity !

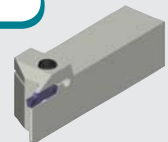

### Blades with shank holders

Available for various machining !

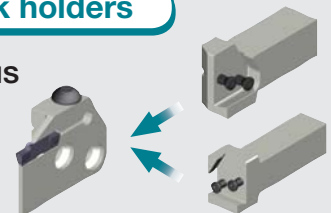

### Blades with tool blocks

Suitable for large diameter machining !

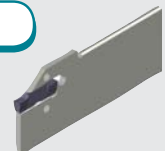

## ● Economical

*MULTI-FUNCTIONAL TOOL REDUCES TOOL SET-UPS*

### Conventional

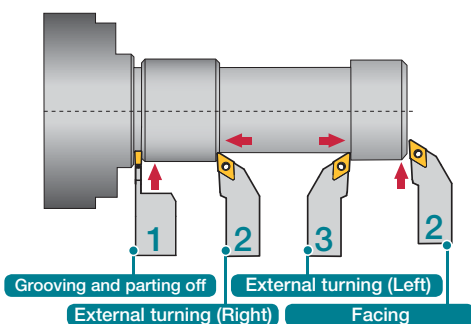

**3 in 1!**

### TUNG CUT

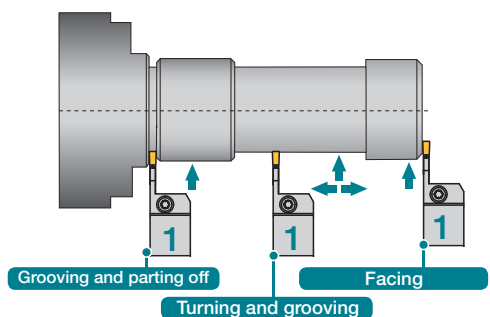

# Cutting performance

## ● Chip control

*Unique chipbreaker provides excellent chip control in various conditions !*

Cutting condition	Carbon steels (S45C)					Stainless steels (SUS304)			
	Feed $f$ (mm/rev)					Feed $f$ (mm/rev)			
	0.10	0.15	0.20	0.25	0.30	0.10	0.15	0.20	0.25
TUNG CUT	Good					Good			
Competitor A	Unstable			With vibration	Unstable				

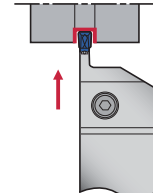

Insert : DGM4-030  
 Toolholder : CTER2525-4T25  
 Groove width :  $W = 4$  mm  
 Cutting speed:  $V_c = 100$  m/min  
 Feed :  $f = 0.1 \sim 0.3$  mm/rev  
 Coolant : Water soluble

# Grades

## ● AH725

*An all-round grade for most materials !*

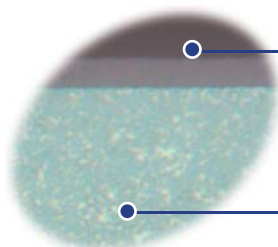

(Ti, Al)N PVD “Super-Flash” coating

Well controlled structure, and very strong coating layer !!  
 Improved adhesion strength!!

Fine grain cemented carbide with high toughness and plastic deformation strength

## ● GH130

*Best use for interrupted or tough cutting !*

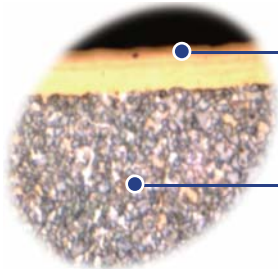

TiCNO PVD coating layer

High hardness and wear resistance

Unique substrate with super high toughness and fracture strength

Grade	Substrate			Coating layer		Features
	Specific gravity	HRA	GPa	Main Composition	Thickness (μm)	
AH725	14.4	91.5	3.0	(Ti, Al)N	2	Well balanced grade with wear and chipping resistance.
GH130	14.1	89.5	-	TiCNO	3	High toughness and excellent chipping resistance. Suitable for heavy machining and roughing.
TH10	14.7	92.0	2.4	-	-	Well balanced grade of wear resistance and toughness suitable for non-ferrous material.

## Insert application

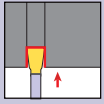
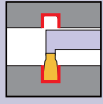
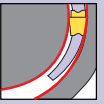
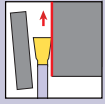
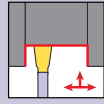
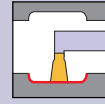
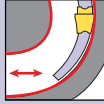
Insert	Application						
	Grooving			Parting off	Turning		
	External	Internal	Face		External	Internal	Face
							
DGS / SGS	●			●			
DGM / SGM	●			●			
DTE	●				●		
DGE	●						
DTX	●	●	●	●	●	●	●
DTI		●				●	
DTF			●				●
DTR	●				●		

## Standard cutting conditions

Work materials	Hardness	Cutting speed Vc (m/min)		
		AH725	GH130	TH10
<b>Steels</b> S45C, SCM435 etc. (C45, 34CrMo4 etc.)	< 300 HB	50 ~ 180	40 ~ 150	-
<b>Stainless steels</b> SUS303, SUS304 etc. (X10CrNiS18-9 etc.)	< 200 HB	50 ~ 120	50 ~ 120	-
<b>Grey cast irons, Ductile cast irons</b> FC250, FCD450 etc. (GG25, GGG45 etc.)	-	-	50 ~ 180	-
<b>Aluminium alloys</b> (Si < 12%) <b>Copper alloys</b>	-	-	-	100 ~ 500
<b>Titanium, Titanium alloys</b> (Ti-6Al-4V etc.)	< 40 HRC	-	20 ~ 80	-

# Features of Inserts

## External grooving and parting off

**DGM type (2 corner)**  
**SGM type (1 corner)**

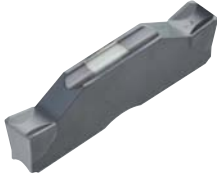

- Smooth chip evacuation
- Well designed edge with high strength
- Handed insert available

■ Standard feed

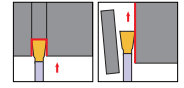
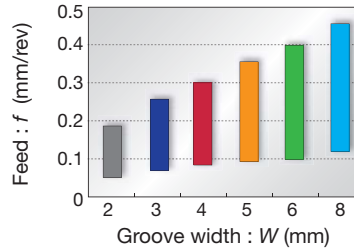

**DGS type (2 corner)**  
**SGS type (1 corner)**



- Sharper edge, and low cutting force
- Unique designed edge and chipbreaker
- Handed insert available

■ Standard feed

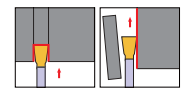
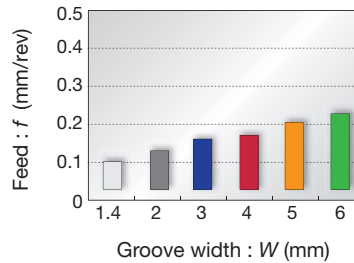

## External grooving and turning

**DTE type (2 corner)**



- Unique breaker makes chips shorter
- Molded and ground insert available

■ Standard feed and DoC

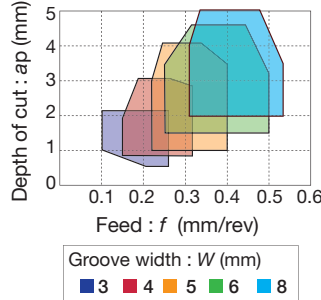

■ Standard feed

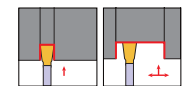
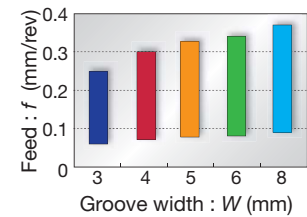

## External, internal, face, grooving and turning

**DTX type (2 corner)**



- Well balanced sharpness and strength
- Multi functional insert

■ Standard feed and DoC

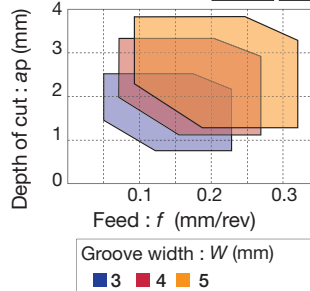

■ Standard feed

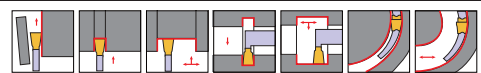
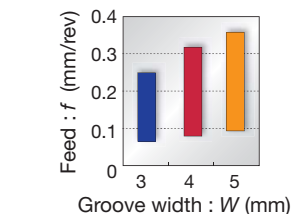

## External grooving

### DGE type (2 corner)



- For narrow grooving
- Excellent chip control
- Ground insert with high accuracy

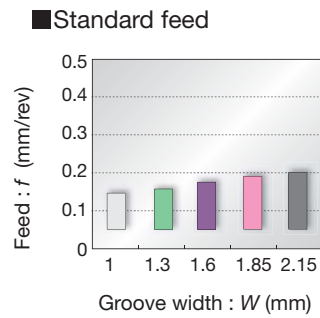

## Profiling and Undercutting

### DTR type (2 corner)

Molded



Ground



- Excellent chip control
- Full radius insert
- Molded and ground insert available

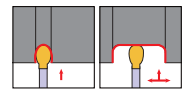
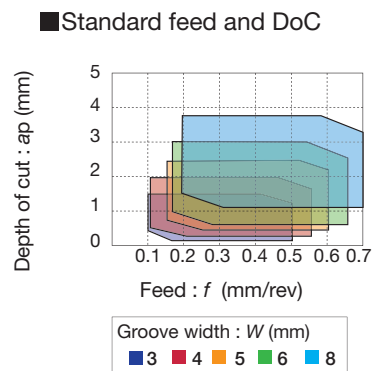

## Internal grooving and turning

### DTI type (2 corner)



- Unique chipbreaker makes chips shorter
- Molded and ground insert available

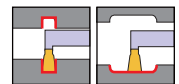
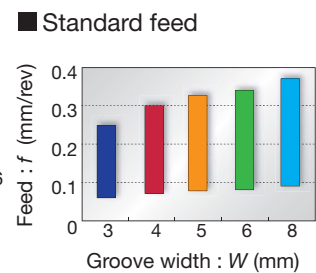
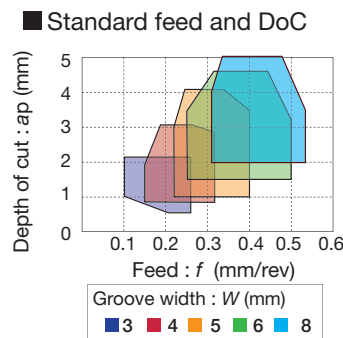

## Face grooving and turning

### DTF type (2 corner)



- Unique chipbreaker makes chips shorter
- Handed insert

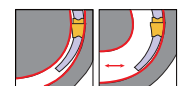
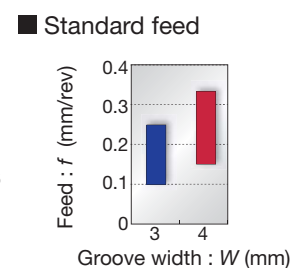
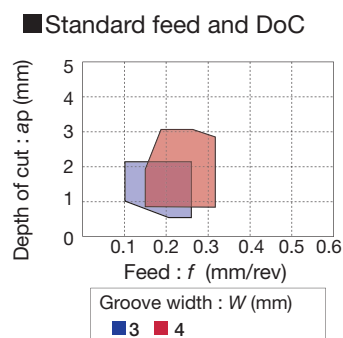



# Inserts

## Notation of "insert seat size"

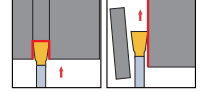
Seat size and grooving width are different. The seat size measure is for the specification of the setting insert. Please note this point.



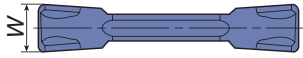
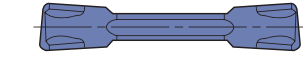
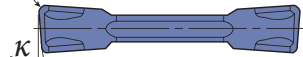

## DGM External grooving and parting off, 2 corner

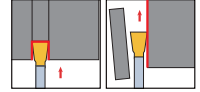
	Insert seat size	Cat. No.	Grades				Dimensions (mm)					
			Coated				$W_{\pm 0.05}$	$r_{\epsilon}$	$L$	$h$	$\kappa$	
			AH725		GH130							
			R	L	R	L						
Neutral 	2	DGM 2-020	●		●		2	0.2	20	5	-	
		DGM 2-020-6R/L	●	●	●	●	2	0.2	20	5	6°	
DGM 2-020-8R/L		●	●	●	●	2	0.2	20	5	8°		
DGM 2-020-15R/L		●	●	●	●	2	0.2	20	5	15°		
DGM 2-002-15R/L		●	●	●	●	2	0.02	19.6	5	15°		
Left hand 	3	DGM 3-020			●		3	0.2	20	5	-	
		DGM 3-020-6R/L	●	●	●	●	3	0.2	20	5	6°	
DGM 3-002-6R/L		●	●	●	●	3	0.02	19.6	5	6°		
DGM 3-020-15R/L		●	●	●	●	3	0.2	20	5	15°		
Right hand 		4	DGM 4-030			●		4	0.3	20	5	-
	DGM 4-030-4R/L		●	●	●	●	4	0.3	20	5	4°	
DGM 4-030-15R/L	●		●	●	●	4	0.3	20	5	15°		
7° 	5		DGM 5-030			●		5	0.3	25	5.5	-
			DGM 5-030-4R	●		●		5	0.3	20	5.5	4°
	6	DGM 6-030			●		6	0.3	25	5.5	-	
	8	DGM 8-040			●		8	0.4	30	6.7	-	

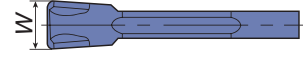
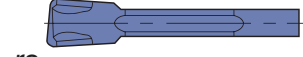
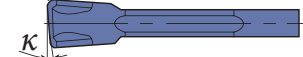

## SGM External deep grooving and parting off, 1 corner

	Insert seat size	Cat. No.	Grades				Dimensions (mm)				
			Coated				$W_{\pm 0.05}$	$r_{\epsilon}$	$L$	$h$	$\kappa$
			AH725		GH130						
			R	L	R	L					
Neutral 	2	SGM 2-020	●		●		2	0.2	20	5	-
		SGM 2-020-6R/L	●	●	●	●	2	0.2	20	5	6°
Left hand 	3	SGM 3-020			●		3	0.2	20	5	-
		SGM 3-020-6R/L	●	●	●	●	3	0.2	20	5	6°
SGM 3-020-15R/L		●	●	●	●	3	0.2	20	5	15°	
Right hand 	4	SGM 4-030			●		4	0.3	20	5	-
		SGM 4-030-4R/L	●	●	●	●	4	0.3	20	5	4°
7° 	5	SGM 5-030			●		5	0.3	25	5.5	-
	6	SGM 6-030			●		6	0.3	25	5.5	-

● : Stocked items



**DTE**

**External grooving and turning (Ground)**

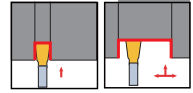

Insert seat size	Cat. No.	Grades Coated		Dimensions (mm)			
		AH725	GH130	$W \pm 0.02$	$r_{\epsilon} \pm 0.05$	$L$	$h$
3	DTE265-015	●	●	2.65	0.15	20	5
	DTE300-020	●	●	3	0.2	20	5
	DTE300-040	●	●	3	0.4	20	5
	DTE315-015	●	●	3.15	0.15	20	5
4	DTE400-040	●	●	4	0.4	20	5
	DTE400-080	●	●	4	0.8	20	5
	DTE415-015	●	●	4.15	0.15	20	5
5	DTE478-055	●	●	4.78	0.55	25	5.5
	DTE500-040	●	●	5	0.4	25	5.5
	DTE500-080	●	●	5	0.8	25	5.5
	DTE515-015	●	●	5.15	0.15	25	5.5
6	DTE600-080	●	●	6	0.8	25	5.5
	DTE600-120	●	●	6	1.2	25	5.5
8	DTE800-080	●	●	8	0.8	30	6.7
	DTE800-120	●	●	8	1.2	30	6.7

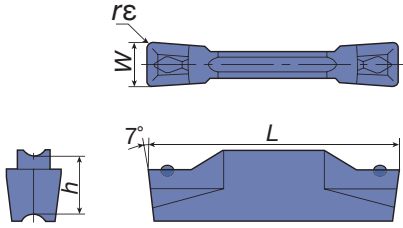

**External grooving and turning (Molded)**

Insert seat size	Cat. No.	Grades Coated		Dimensions (mm)			
		AH725	GH130	$W \pm 0.05$	$r_{\epsilon}$	$L$	$h$
3	DTE3-040	●	●	3	0.4	20	5
4	DTE4-040	●	●	4	0.4	20	5

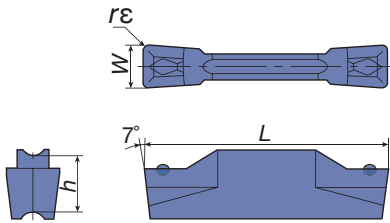

**DTX**

**Face grooving, external and internal turning**

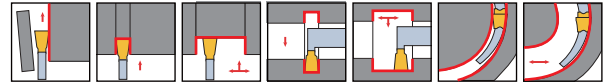

Insert seat size	Cat. No.	Grades Coated		Dimensions (mm)			
		AH725	GH130	$W \pm 0.05$	$r_{\epsilon} \pm 0.05$	$L$	$h$
3	DTX3-030	●	●	3	0.3	20	5
4	DTX4-040	●	●	4	0.4	20	5
5	DTX5-040	●	●	5	0.4	25	5.5

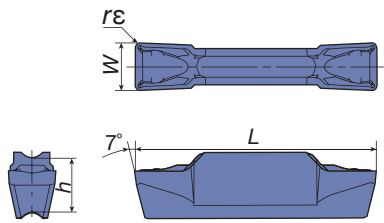

**DTF**

**Face grooving and turning**

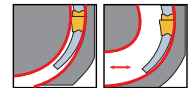

Insert seat size	Cat. No.	Grades Coated				Dimensions (mm)			
		AH725		GH130		$W \pm 0.05$	$r_{\epsilon}$	$L$	$h$
		R	L	R	L				
		3	DTF3-040-R/L	●	●	●	●	3	0.4
4	DTF4-040-R/L	●	●	●	●	4	0.4	20	5

Right hand (R) shown.

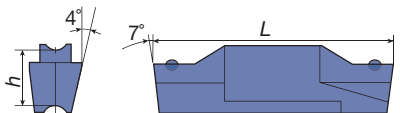

● : Stocked items

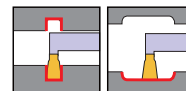

## DTI Internal grooving and turning (Ground)

	Insert seat size	Cat. No.	Grades		Dimensions (mm)			
			Coated		$W \pm 0.02$	$r\epsilon \pm 0.05$	$L$	$h$
			AH725	GH130				
	3	DTI300-040	●	●	3	0.4	20	5
	4	DTI400-040	●	●	4	0.4	20	5
		DTI400-080	●	●	4	0.8	20	5
	5	DTI500-040	●	●	5	0.4	25	5.5
		DTI500-080	●	●	5	0.8	25	5.5
	6	DTI600-080	●	●	6	0.8	25	5.5
		DTI600-120	●	●	6	1.2	25	5.5
	8	DTI800-080	●	●	8	0.8	30	6.7
DTI800-120		●	●	8	1.2	30	6.7	

## Internal grooving and turning (Molded)

	Insert seat size	Cat. No.	Grades		Dimensions (mm)			
			Coated		$W \pm 0.05$	$r\epsilon$	$L$	$h$
			AH725	GH130				
	3	DTI3-040	●	●	3	0.4	20	5
	4	DTI4-040	●	●	4	0.4	20	5

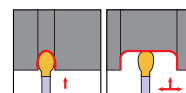

## DTR External grooving, turning and profiling (Molded)

	Insert seat size	Cat. No.	Grades		Dimensions (mm)			
			Coated		$W \pm 0.05$	$r\epsilon$	$L$	$h$
			AH725	GH130				
	3	DTR3-150	●	●	3	1.5	20	5
	4	DTR4-200	●	●	4	2	20	5
	5	DTR5-250	●	●	5	2.5	25	5.5
	6	DTR6-300	●	●	6	3	25	5.5
	8	DTR8-400	●	●	8	4	30	6.7

## External grooving, turning and profiling (Ground)

	Insert seat size	Cat. No.	Grades		Dimensions (mm)			
			Coated		$W \pm 0.02$	$r\epsilon$	$L$	$h$
			AH725	GH130				
	3	DTR300-150	●	●	3	1.5	20	5
	4	DTR400-200	●	●	4	2	20	5
	5	DTR478-239	●	●	4.78	2.39	25	5.5
		DTR500-250	●	●	5	2.5	25	5.5
	6	DTR600-300	●	●	6	3	25	5.5

● : Stocked items

# Toolholders

## ● Mono block type

### CTE R/L

### External grooving and turning

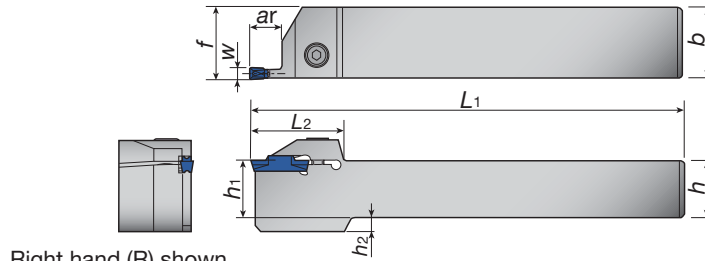
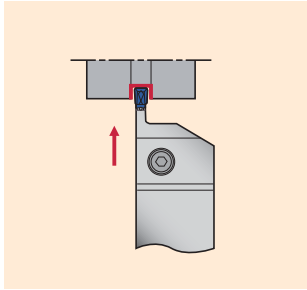

Right hand (R) shown.

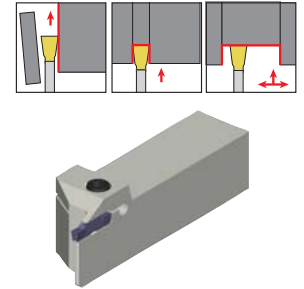

Insert seat size	Cat. No.	Stock		*Max. groove depth ar (mm)	Dimensions (mm)							Inserts	Parts		
		R	L		h <sub>1</sub>	b	h	L <sub>1</sub>	**f	W	h <sub>2</sub>		L <sub>2</sub>	Clamping screw	Wrench
2	CTER/L1616-2T08	●	●	8	16	16	16	110	16.1	2	4	33	DGM/SGM DGS/SGS DGE DTX DTE DTR	CM5x0.8x16-A	P-4
	CTER/L2020-2T08	●	●	8	20	20	20	125	20.1	2	-	33		CM5x0.8x20-A	
	CTER/L2525-2T08	●	●	8	25	25	25	150	25.1	2	-	33		CM5x0.8x25-A	
	CTER/L1616-2T12	●	●	12	16	16	16	110	16.1	2	4	32		CM5x0.8x16-A	
	CTER/L2020-2T12	●	●	12	20	20	20	125	20.1	2	-	32		CM5x0.8x20-A	
	CTER/L2525-2T12	●	●	12	25	25	25	150	25.1	2	-	32		CM5x0.8x25-A	
	CTER/L1616-2T17	●	●	17	16	16	16	110	16.1	2	4	37		CM5x0.8x16-A	
	CTER/L2020-2T17	●	●	17	20	20	20	125	20.1	2	-	37		CM5x0.8x20-A	
	CTER/L2525-2T17	●	●	17	25	25	25	150	25.1	2	-	37		CM5x0.8x25-A	
3	CTER/L1616-3T09	●	●	9	16	16	16	110	16.3	3	4	32	DGM/SGM DGS/SGS DGE DTX DTE DTR	CM5x0.8x16-A	P-4
	CTER/L2020-3T09	●	●	9	20	20	20	125	20.3	3	-	32		CM5x0.8x20-A	
	CTER/L2525-3T09	●	●	9	25	25	25	150	25.3	3	-	32		CM5x0.8x25-A	
	CTER/L1616-3T20	●	●	20	16	16	16	110	16.3	3	4	38.5		CM5x0.8x16-A	
	CTER/L2020-3T20	●	●	20	20	20	20	125	20.3	3	-	38.5		CM5x0.8x20-A	
	CTER/L2525-3T20	●	●	20	25	25	25	150	25.3	3	-	38.5		CM5x0.8x25-A	
	CTER/L2525-3T25	●	●	25	25	25	25	150	25.3	3	-	44.5		CM5x0.8x25-A	
	CTER/L1616-4T10	●	●	10	16	16	16	110	16.5	4	4	32		CM6x1x16-A	
CTER/L2020-4T10	●	●	10	20	20	20	125	20.5	4	-	32	CM6x1x20-A			
4	CTER/L2525-4T10	●	●	10	25	25	25	150	25.5	4	-	32	CM6x1x25-A	P-5	
	CTER/L1616-4T25	●	●	25	16	16	16	110	16.5	4	4	45	CM6x1x16-A		
	CTER/L2020-4T25	●	●	25	20	20	20	125	20.5	4	-	45	CM6x1x20-A		
	CTER/L2525-4T25	●	●	25	25	25	25	150	25.5	4	-	45	CM6x1x25-A		
	CTER/L3232-4T25	●	●	25	32	32	32	170	32.5	4	-	45	CM6x1x25-A		
	CTER/L2020-5T12	●	●	12	20	20	20	125	20.6	5	-	37	CM6x1x20-A		
	CTER/L2525-5T12	●	●	12	25	25	25	150	25.6	5	-	37	CM6x1x25-A		
5	CTER/L2525-5T32	●	●	32	25	25	25	150	25.5	5	-	56	CM6x1x25-A		
	CTER/L3232-5T32	●	●	32	32	32	32	170	32.5	5	-	56	CM6x1x25-A		
	CTER/L2020-6T12	●	●	12	20	20	20	125	20.6	6	-	37	CM8x1.25x20-A	P-6	
	CTER/L2525-6T12	●	●	12	25	25	25	150	25.6	6	7	37			
CTER/L2525-6T32	●	●	32	25	25	25	150	25.5	6	7	56				
CTER/L3232-6T32	●	●	32	32	32	32	170	32.5	6	-	56				
8	CTER/L2525-8T16	●	●	16	25	25	25	150	26.1	8	7	47	CM8x1.25x20-A	P-6	
	CTER/L2525-8T25	●	●	25	25	25	25	150	26.1	8	7	47			
	CTER/L3232-8T25	●	●	25	32	32	32	170	33.1	8	-	47			
	CTER/L2525-8T36	●	●	36	25	25	25	150	26.1	8	7	60			
	CTER/L3232-8T36	●	●	36	32	32	32	170	33.1	8	-	60			

\* When depth is deeper than insert length, 1 corner type is recommended.

\*\* "f" value in the above table is calculated with groove width "W" shown in the table.

# CTI R/L

## Internal grooving, turning and profiling

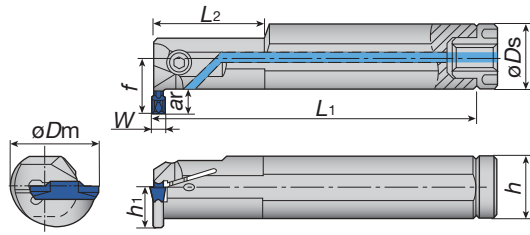
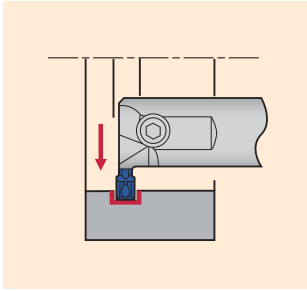

Right hand (R) shown.

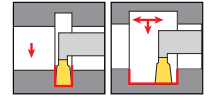
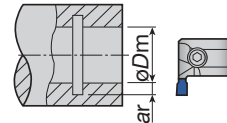

Insert seat size	Cat. No.	Stock		Min. dia. øDm (mm)	Max. groove depth ar (mm)	Dimensions (mm)							Inserts	Parts			
		R	L			øDs	h <sub>1</sub>	h	*L <sub>1</sub>	f	W	L <sub>2</sub>		Clamping screw	Wrench	Seal cap	Internal screw
3	CTIR/L20-3T06-D250	●	●	25	6	20	9	18	160	15.8	3	40	DTI DTX	CM5x0.8x12-A	P-4	CA-20	M6
	CTIR/L25-3T05-D250	●	●	25	5.1	25	11.5	23	200	17.5	3	40				CM5x0.8x16-A	CA-25
	CTIR/L25-3T08-D320	●	●	32	8	25	11.5	23	200	21.5	3	40		CM5x0.8x16-A			CA-32
	CTIR/L32-3T10-D400	●	●	40	10	32	15	30	250	27	3	60				CA-32	
4	CTIR/L20-4T06-D250	●	●	25	6	20	9	18	160	15.8	4	40		CM5x0.8x12-A	P-4	CA-20	M6
	CTIR/L25-4T08-D320	●	●	32	8	25	11.5	23	200	21.5	4	40				CM5x0.8x16-A	CA-25
	CTIR/L32-4T04-D310	●	●	31	4	32	15	30	250	20.8	4	60		CM5x0.8x16-A			CA-32
	CTIR/L32-4T10-D400	●	●	40	10	32	15	30	250	27	4	60				CA-32	
5	CTIR/L25-5T05-D310	●	●	31	5	25	11.5	23	200	17.3	5	60		CM6x1x16-A	P-5	CA-25	R1/8"
	CTIR/L32-5T10-D400	●	●	40	10	32	15	30	250	27	5	60				CM6x1x20-A	
6	CTIR/L32-6T04-D310	●	●	31	4	32	15	30	250	20.8	6	60		CM6x1x20-A	P-5	CA-32	R1/8"
	CTIR/L32-6T10-D400	●	●	40	10	32	15	30	250	27	6	60				CA-32	
8	CTIR/L32-8T05-D370	●	●	37	5	32	15	30	250	21.3	8	60	CM6x1x25-A	P-5	CA-32	R1/8"	
	CTIR/L40-8T05-D420	●	●	42	5.8	40	19	38	300	25.8	8	65			CA-40		

\* "L<sub>1</sub>" value in the above table is calculated with groove width "W" shown in the table.

### Caution

Min. diameter, øDm, in above table is calculated with DTI or DTX type insert. When using other types, please see the øDm shown in the table on the right.

Inserts	øDm (mm)	Note
DGS / DGM 3	ø50	When diameter is smaller than øDm, DTI or DTX type insert is recommended.
DGS / DGM 4	ø50	
DGS / DGM 5	ø60	
DGS / DGM 6	ø60	
DTE 3	ø40	
DTE 4	ø40	
DTE 5	ø50	
DTE 6	ø50	

● : Stocked items

**CTF R/L**

**Deep face grooving and turning**

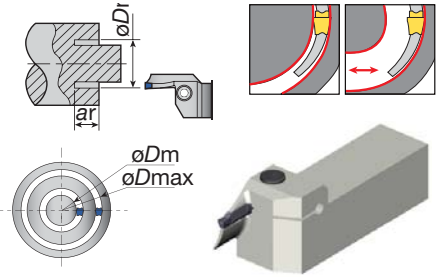
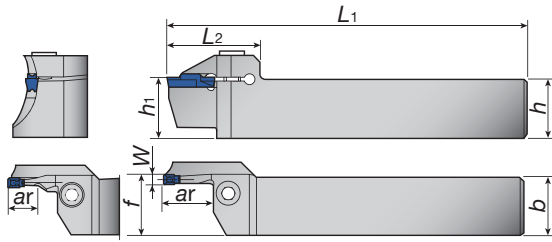
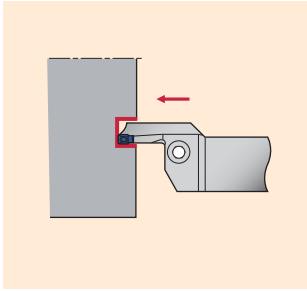

Right hand (R) shown.

Insert seat size	Cat. No.	Stock		Min. dia. $\phi D_m$ (mm)	Max. dia. $\phi D_m$ (mm)	*Max. groove depth ar (mm)	Dimensions (mm)						*** Inserts	Parts		
		R	L				$h_1$	$b$	$h$	$L_1$	**f	W		$L_2$	Clamping screw	Wrench
3	CTFR/L2525-3T10-024035	●	●	24	35	10	25	25	25	150	25.5	3	38	DTF / DTX / DTE / DGM / DGS	CM6x1x25-A	P-5
	CTFR/L2525-3T10-029040	●	●	29	40	10	25	25	25	150		3	38			
	CTFR/L2525-3T10-034050	●	●	34	50	10	25	25	25	150		3	38			
	CTFR/L2525-3T15-044070	●	●	44	70	15	25	25	25	150		3	38			
	CTFR/L2525-3T15-064100	●	●	64	100	15	25	25	25	150		3	38			
4	CTFR/L2525-4T10-022036	●	●	22	36	10	25	25	25	150	25.6	4	39	DTF / DTX / DTE / DGM / DGS	CM6x1x25-A	P-5
	CTFR/L2525-4T20-028042	●	●	28	42	20	25	25	25	150		4	39			
	CTFR/L2525-4T20-034050	●	●	34	50	20	25	25	25	150		4	39			
	CTFR/L2525-4T20-042070	●	●	42	70	20	25	25	25	150		4	39			
	CTFR/L2525-4T20-062120	●	●	62	120	20	25	25	25	150		4	39			
	CTFR/L2525-4T20-112200	●	●	112	200	20	25	25	25	150		4	39			
5	CTFR/L2525-5T25-050080	●	●	50	80	25	25	25	25	150	25.6	5	49	DTX / DTE / DGM / DGS	CM8x1.25x25-A	P-6
	CTFR/L2525-5T25-070110	●	●	70	110	25	25	25	25	150		5	49			
	CTFR/L2525-5T25-100150	●	●	100	150	25	25	25	25	150		5	49			
	CTFR/L2525-5T25-140200	●	●	140	200	25	25	25	25	150		5	49			
6	CTFR/L2525-6T25-048070	●	●	48	70	25	25	25	25	150	25.6	6	49	DTE / DGM / DGS	CM8x1.25x25-A	P-6
	CTFR/L2525-6T25-058100	●	●	58	100	25	25	25	25	150		6	49			
	CTFR/L2525-6T25-088180	●	●	88	180	25	25	25	25	150		6	49			
	CTFR/L2525-6T25-168400	●	●	168	400	25	25	25	25	150		6	49			

\* When depth is deeper than insert length, 1 corner type is recommended.

\*\* "f" value in the above table is calculated with groove width "W" shown in the table.

**Caution**

In DTF and DTX insert types, seat size "6" inserts are not available. When 6 size insert is required, the DGM or DGS type is recommended.

\*\*\* Min. diameter  $\phi D_m$  of DTE insert

Inserts	$\phi D_m$ (mm)	Note
DTE 3	$\phi 44$	When diameter is smaller than $\phi D_m$ , DTI or DTX type insert is recommended.
DTE 4	$\phi 42$	
DTE 5	$\phi 50$	
DTE 6	$\phi 48$	

● : Stocked items

## CGE R/L

### Deep grooving and parting off

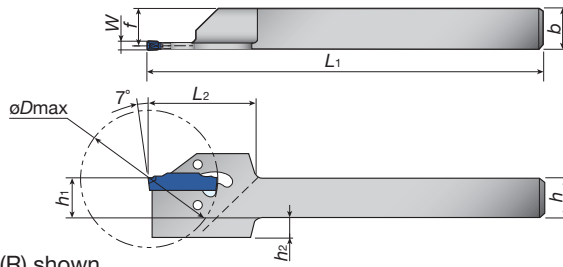
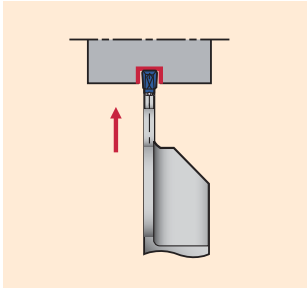

Right hand (R) shown.

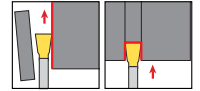

Insert seat size	Cat. No.	Stock		Max. dia. $\phi D_m$ (mm)	Max. groove depth $r$ (mm)	Dimensions (mm)							Inserts	Parts Wrench		
		R	L			DGS/M	SGS/M	$h_1$	$b$	$h$	$L_1$	$^*f$			$W$	$h_2$
1	CGER/L2020-1.4T14	●	●	29	29	9.7	20	20	20	125	20.2	1.4	-	30	DGM/SGM DGS/SGS	CRW23
	CGER/L1212-2T17	●	●	35	35	11.8	12	12	12	150	12.1	2	6	30		CRW33
2	CGER/L1616-2T17	●	●	35	35	11.8	16	16	16	150	16.1	2	2	30		CRW33
	CGER/L2020-2T17	●	●	35	35	9.8	20	20	20	125	20.1	2	-	30		CRW33
3	CGER/L1212-3T19	●	●	38	40	12	12	12	12	150	12.3	3	6	30		CRW33
	CGER/L1616-3T19	●	●	38	45	14.9	16	16	16	150	16.3	3	2	30		CRW33
4	CGER/L2020-3T19	●	●	38	45	13.2	20	20	20	125	20.3	3	-	30	CRW33	
	CGER/L2020-4T19	●	●	38	55	20.3	20	20	20	125	20.4	4	-	32	CRW33	

\* "f" value in the above table is calculated with groove width "W" shown in the table.

## CGP

### Deep grooving and parting off

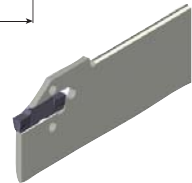
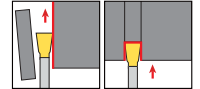
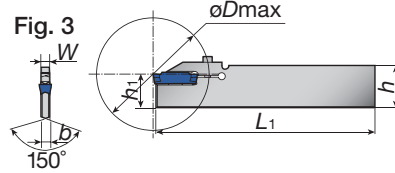
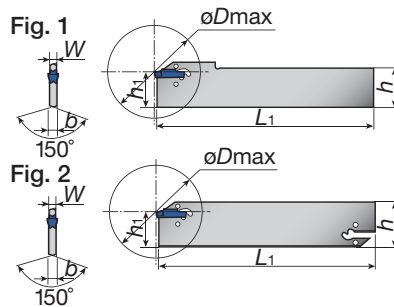
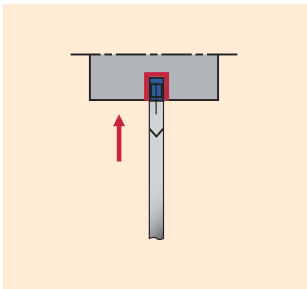

Insert seat size	Cat. No.	Stock	*Max. parting off dia. $\phi D_m$ (mm)	Dimensions (mm)					Inserts	Parts		Shape
				$h_1$	$b$	$h$	$L_1$	$W$		Clamping screw	Wrench	
1	CGP 26-1.4S	●	26	1.4	1	26	150	1.4	DGS1.4-016	-	CRW23	Fig. 1
	CGP 32-1.4D	●	25	1.4	1	32	150	1.4		CRW23	Fig. 2	
2	CGP 26-2S	●	40	2	1.8	26	150	2	SGM	-	CRW33	Fig. 1
	CGP 32-2D	●	50	2	1.8	32	150	2		CRW33	Fig. 2	
3	CGP 26-3S	●	50	3	2.4	26	150	3	SGS	-	CRW33	Fig. 1
	CGP 32-3D	●	100	3	2.4	32	150	3		CRW33	Fig. 2	
4	CGP 26-4S	●	80	4	3.2	26	150	4	SGS	-	CRW33	Fig. 1
	CGP 32-4D	●	100	4	3.2	32	150	4		CRW33	Fig. 2	
	CGP 45-4D	●	120	4	3.2	45	150	4				
5	CGP 32-5D	●	120	5	4	32	150	5		-	CRW33	Fig. 2
6	CGP 32-6D	●	120	6	5.2	32	150	6		-	CRW33	Fig. 2
8	CGP 32-8S-CL	●	80	8	6.2	32	150	8		CM4x0.7x20-MO-A	P-3	Fig. 3

### Caution

Wrench, CRW□□, should be ordered separately.

### Newly developed wrench

Insert is clamped by the elastic deformation of upper jaw.  
Low clamping stress increases the stability and tool life.

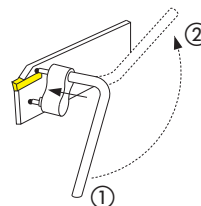

① → ② : unclamp  
② → ① : clamp

● : Stocked items

# ● Tool block for CGP blades

## CTBF / CTBU Deep grooving and parting off

CTBF type

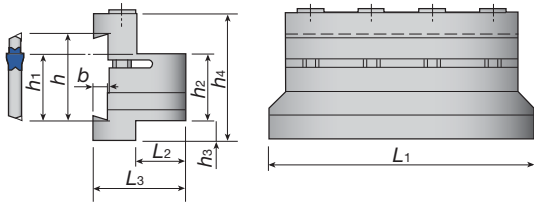

CTBU type

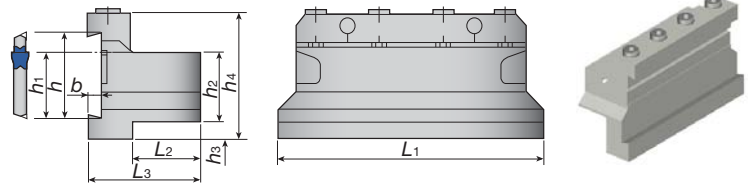

Cat. No.	Stock	Dimensions (mm)									Blade	Parts		
		$h_1$	$b$	$h$	$L_1$	$h_2$	$h_3$	$h_4$	$L_2$	$L_3$		Clamping screw	Clamp	Wrench
CTBF25-45	●	38.1	5.5	45	110	25	25	66	22	40	CGP	CM6x1.0x40-A	-	P-5
CTBF32-45	●	38.1	5.5	45	120	32	18	66	28	45		CM6x1.0x40-A	-	
CTBU20-26	●	21.4	4	26	86	20	9	43	21	38		CM6x30-S	CT-86	
CTBU25-26	●	21.4	4	26	110	25	5	45	23	42		CM6x30-S	CT-100	
CTBU20-32	●	24.8	5.3	32	100	20	13	50	19	38		CM6x30-S	CT-105	
CTBU25-32	●	24.8	5.3	32	110	25	8	50	23	42		CM6x30-S	CT-110	
CTBU32-32	●	24.8	5.3	32	110	32	5	54	29	48		CM6x30-S	CT-110	

## JCTE R/L For small lathe

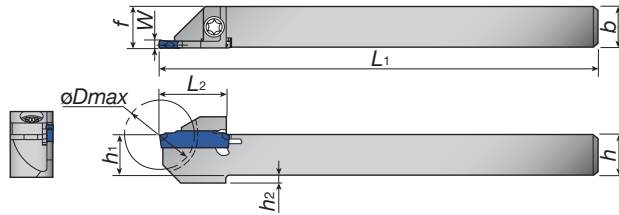
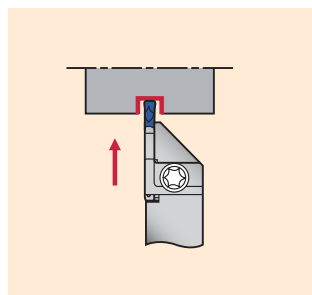

Right hand (R) shown.



Insert seat size	Cat. No.	Stock		Max. dia. $\phi D_m$ (mm)	Dimensions (mm)							Inserts	Parts			
		R	L		$h_1$	$b$	$h$	$L_1$	$^*f$	$W$	$h_2$		$L_2$	Clamping screw	Wrench	
1	JCTER/L1010-1.4T10			20	10	10	10	125	10.2	1.4	-	18	DGM/SGM DGS/SGS	CSHB-4-A	T-15F	
	JCTER/L1212-1.4T12			24	12	12	12	125	12.2	1.4	-	19.5				
	JCTER/L1414-1.4T12			24	14	14	14	125	14.2	1.4	-	19.5				
	JCTER/L1616-1.4T16			32	16	16	16	125	16.2	1.4	-	24				
2	JCTER/L1010-2T10			20	10	10	10	125	10.1	2	2	19		DGE DTE DTR	CSHB-4-A	T-15F
	JCTER/L1212-2T12			24	12	12	12	125	12.1	2	2	19				
	JCTER/L1414-2T12			24	14	14	14	125	14.1	2	-	19				
	JCTER/L1616-2T16			32	16	16	16	125	16.1	2	-	24				
3	JCTER/L1212-3T12			24	12	12	12	125	12.3	3	-	19	CSHB-4-A	T-15F		
	JCTER/L1616-3T16			32	16	16	16	125	16.3	3	-	24				
	JCTER/L2020-3T16			32	20	20	20	125	20.3	3	-	24				

\* "f" value in the above table is calculated with groove width "W" shown in the table.

● : Stocked items

## ● Blades (For general purpose)

### CAE R/L

### External grooving and turning

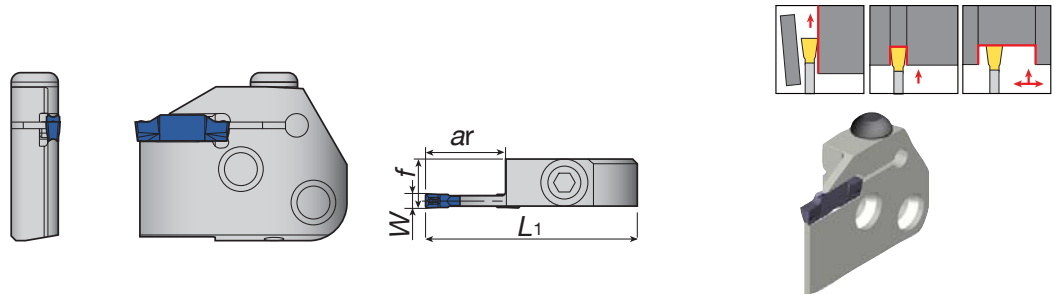

Right hand (R) shown.

Insert seat size	Cat. No.	Stock		*Max. groove depth ar (mm)	Dimensions (mm)			Inserts	Shank	Parts	
		R	L		L <sub>1</sub>	f	W			Clamping screw	Wrench
3	CAER/L-3T16	●	●	16	45	10.4	3	DGS / SGS DGM / SGM DTX DTE DTR	CHFVR/L CHSR/L	BHM6-20-A	P-4
4	CAER/L-4T16	●	●	16	45	10.5	4				
5	CAER/L-5T20	●	●	20	49	10.5	5				
6	CAER/L-6T20	●	●	20	49	10.5	6				

### CAF R/L

### Face grooving and turning

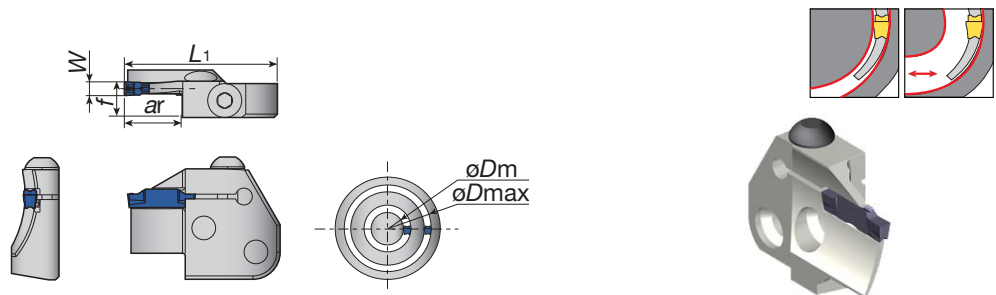

Right hand (R) shown.

Insert seat size	Cat. No.	Stock		Min. dia. øDm (mm)	Max. dia. øDm (mm)	Max. groove depth ar (mm)	Dimensions (mm)			Inserts	Shank	Parts	
		R	L				L <sub>1</sub>	f	W			Clamping screw	Wrench
3	CAFR/L-3T12-040055	●	●	40	55	12	12	10.4	3	DTF	CHFVR/L CHSR/L	BHM6-20-A	P-4
	CAFR/L-3T12-055075	●	●	55	75	12	12	10.4	3				
	CAFR/L-3T12-075100	●	●	75	100	12	12	10.4	3				
	CAFR/L-3T12-100140	●	●	100	140	12	12	10.4	3				
	CAFR/L-3T12-140200	●	●	140	200	12	12	10.4	3				
4	CAFR/L-4T16-050070	●	●	50	70	16	16	10.5	4				
	CAFR/L-4T16-070100	●	●	70	100	16	16	10.5	4				
	CAFR/L-4T16-100150	●	●	100	150	16	16	10.5	4				
	CAFR/L-4T16-150250	●	●	150	250	16	16	10.5	4				
5	CAFR/L-5T20-055080	●	●	55	80	20	20	10.5	5				
	CAFR/L-5T20-080120	●	●	80	120	20	20	10.5	5				
	CAFR/L-5T20-120180	●	●	120	180	20	20	10.5	5				
	CAFR/L-5T20-180300	●	●	180	300	20	20	10.5	5				
	CAFR/L-5T20-300000	●	●	300	∞	20	20	10.5	5				
6	CAFR/L-6T25-060090	●	●	60	90	25	25	10.5	6				
	CAFR/L-6T25-090150	●	●	90	150	25	25	10.5	6				
	CAFR/L-6T25-150250	●	●	150	250	25	25	10.5	6				
	CAFR/L-6T25-250400	●	●	250	400	25	25	10.5	6				

● : Stocked items

## ● Toolholders for blades

### CHFV R/L Horizontal type

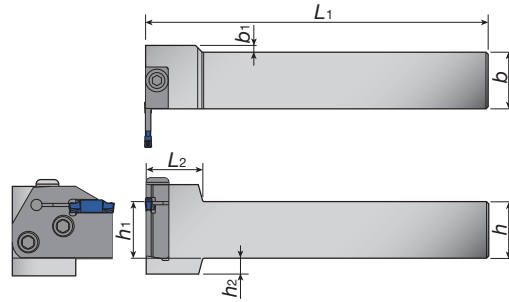

Right hand (R) shown.

Cat. No.	Stock		Dimensions (mm)							Blades	Parts	
	R	L	$h_1$	$b$	$h$	$L_1$	$b_1$	$h_2$	$L_2$		Clamping screw	Wrench
CHFVR/L2020	●	●	20	20	20	150	8	12	25	CAER/L CAFR/L	CSHB-6-A	P-4
CHFVR/L2525	●	●	25	25	25	150	3	7	25			
CHFVR/L3232	●	●	32	32	32	170	-	-	25			

#### ■ Combination of blade and toolholder

Toolholders	Blades			
	CAER□□□	CAEL□□□	CAFR□□□	CAFL□□□
CHFVR***		●		●
CHFVL***	●		●	

### CHS R/L Vertical type

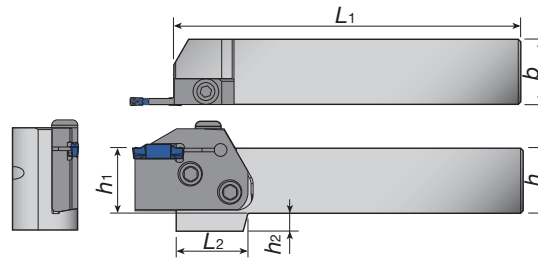

Right hand (R) shown.

Cat. No.	Stock		Dimensions (mm)						Blades	Parts	
	R	L	$h_1$	$b$	$h$	$L_1$	$h_2$	$L_2$		Clamping screw	Wrench
CHSR/L2020	●	●	20	20	20	133	12	35	CAER/L CAFR/L	CSHB-6-A	P-4
CHSR/L2525	●	●	25	25	25	133	7	28			
CHSR/L3232	●	●	32	32	32	153	-	28			

#### ■ Combination of blade and toolholder

Toolholders	Blades			
	CAER□□□	CAEL□□□	CAFR□□□	CAFL□□□
CHSR***	●		●	
CHSL***		●		●

● : Stocked items

## ■ Notice in “turning”

When turning, the insert is pushed by the directional cutting force feed. As a result of this condition the diameter of the workpiece may change. (see picture on right) In such cases, trial cutting is essential to measure the actual diameter. For your reference, the compensated values (SAMPLES) are shown in the following graph.

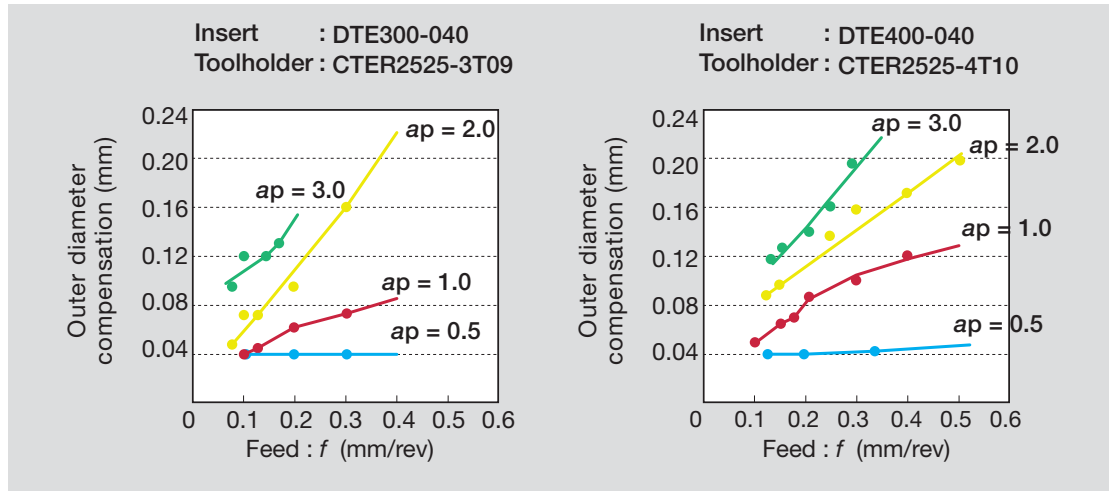
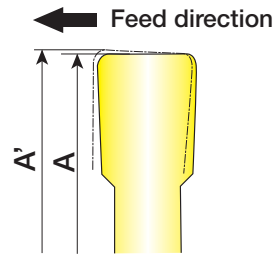

## Practical Examples

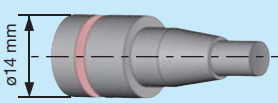
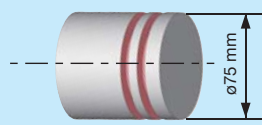
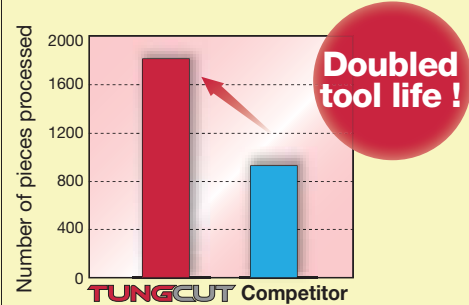
Work piece type		Automotive parts	Machine parts
Toolholder		CTER1616-2T08	CTER2525-4T10
Insert		DGM2-020	DGM4-030
Grade		AH725	AH725
Work material		SCr440, 41Cr4	SCr440, 41Cr4
			
Cutting conditions	Cutting speed: $V_c$ (m/min)	2	4
	Feed : $f$ (mm/rev)	94	150
	Depth of cut: $a_p$ (mm)	0.08	0.10
	Machining	Parting off	Grooving (Depth 6 mm)
	Coolant	Water soluble	Water soluble
Results		 <p><b>TungCut has higher wear resistance and achieves tool life improvements of 150%.</b></p>	 <p><b>TungCut provides better chip control and doubles tool life.</b></p>



## **Tungaloy Corporation (Head office)**

11-1 Yoshima-Kogyodanchi  
Iwaki-city, Fukushima, 970-1144 Japan  
Phone: +81-246-36-8501 Fax: +81-246-36-8542  
<http://www.tungaloy.co.jp/>

## **Tungaloy America, Inc.**

1226A Michael Drive, Wood Dale, IL.60191, U.S.A.  
Phone: +1-630-227-3700 Fax: +1-630-227-0690  
<http://www.tungaloyamerica.com/>

## **Tungaloy Canada**

432 Elgin St. Unit 3, Brantford, Ontario N3S 7P7, Canada  
Phone: +1-519-758-5779 Fax: +1-519-758-5791  
<http://www.tungaloyamerica.com/>

## **Tungaloy de Mexico S.A.**

C Los Arellano 113, Parque Industrial Siglo XXI  
Aguascalientes, AGS, Mexico 20290  
Phone: +52-449-929-5410 Fax: +52-449-929-5411  
<http://www.tungaloyamerica.com/>

## **Tungaloy do Brasil Comércio de Ferramentas de Corte Ltda.**

Rua dos Sabias N.104  
13280-000 Vinhedo, São Paulo, Brazil  
Phone: +55-19-38262757 Fax: +55-19-38262757  
<http://www.tungaloy.co.jp/br/>

## **Tungaloy Germany GmbH**

Elisabeth-Selbert-Strasse 3  
D-40764 Langenfeld, Germany  
Phone: +49-2173-90420-0 Fax: +49-2173-90420-19  
<http://www.tungaloy-eu.com/>

## **Tungaloy France S.A.S.**

6 Avenue des Andes  
F-91952 Courtaboeuf Cedex, France  
Phone: +33-1-6486-4300 Fax: +33-1-6907-7817  
<http://www.tungaloy-eu.com/>

## **Tungaloy Italia S.r.l.**

Via E. Andolfato 10  
I-20126 Milano, Italy  
Phone: +39-02-252012-1 Fax: +39-02-252012-65  
<http://www.tungaloy-eu.com/>

## **Tungaloy Czech s.r.o**

Tuřanka 115  
CZ-627 00 Brno, Czech Republic  
Phone: +420-532 123 391 Fax: +420-532 123 392  
<http://www.tungaloy.co.jp/cz/>

## **Tungaloy Ibérica S.L.**

C/La Pau, nº46  
E-08243 Manresa (BCN), SPAIN  
Phone: +34 93 1131360 Fax: +34 93 1131361  
<http://www.tungaloy.co.jp/es/>

Distributed by:

## **Tungaloy Scandinavia AB**

S:t Lars Väg 42A  
SE-22270 Lund, Sweden  
Phone: +46-462119200 Fax: +46-462119207  
<http://www.tungaloy.co.jp/se/>

## **LLC Tungaloy Rus**

Grazhdanskiy Prospectus, 29a  
Belgorod, 308019, Russia  
Phone: +7 4722 33 97 23 Fax: +7 4722 33 97 23  
<http://www.tungaloy.co.jp/ru/>

## **Tungaloy Polska Sp. z o.o.**

ul. Genevska 24  
03-963 Warszawa, Poland  
Phone: +48-22-617-0890 Fax: +48-22-617-0890  
<http://www.tungaloy.co.jp/pl/>

## **Tungaloy Cutting Tool (Shanghai) Co.,Ltd.**

Rm No 401 No.88 Zhabei, Jiangchang No.3 Rd  
Shanghai 200436, China  
Phone: +86-21-3632-1880 Fax: +86-21-3621-1918  
<http://www.tungaloy.co.jp/tcts/>

## **Tungaloy Cutting Tool (Thailand) Co.,Ltd.**

11th Floor, Sorachai Bldg. 23/7, Soi Sukhumvit 63  
Klongtonnue, Wattana, Bangkok 10110, Thailand  
Phone: +66-2-714-3130 Fax: +66-2-714-3134  
<http://www.tungaloy.co.th/>

## **Tungaloy Singapore (Pte.), Ltd.**

50 Kallang Avenue #06-03 Noel Corporate Building  
Singapore 339505  
Phone: +65-6391-1833 Fax: +65-6299-4557  
<http://www.tungaloy.co.jp/tspl/>

## **Tungaloy India Pvt. Ltd.**

201, 2nd Floor, Krishna Apra Business Square,  
Netaji Subhash Place, Pitampura, Delhi - 110 034, India  
Phone: +91-11-4707-1111 Fax: +91-11-4707-1100  
<http://www.tungaloy.co.jp/in/>

## **Tungaloy Korea Co., Ltd**

#1312, Byucksan Digital Valley 5-cha  
60-73 Gasan-dong, Geumcheon-gu  
153-788 Seoul, Korea  
Phone: +82-2-6393-8930 Fax: +82-2-6393-8952  
<http://www.tungaloy.co.jp/kr/>

## **Tungaloy Malaysia Sdn Bhd**

50 K-2, Kelana Mall, Jalan SS6/14, Kelana Jaya, 47301  
Petaling Jaya, Selangor Darul Ehsan, Malaysia  
Phone: +603-7805-3222 Fax: +603-7804-8563  
<http://www.tungaloy.co.jp/my/>



ISO 9001 certified  
QC00J0056  
Tungaloy Corporation  
18/10/1996

ISO 14001 certified  
EC97J1123  
Tungaloy Group  
Japan site and Asian  
production site  
26/11/1997