

Square shoulder TAC Mill TPD/EPD type

TUNGQUAD

NEW

Highly efficient small diameter cutter



Features and Benefits

High Efficiency

It features excellent chip evacuation and has been designed with high density teeth to maximize the feed rate.

High Durability

Nickel plating body for extended body life.

Economical

With 4-edged on I.C. $\varnothing 5.09$ insert



Cutting Performance (BT30 M/C)

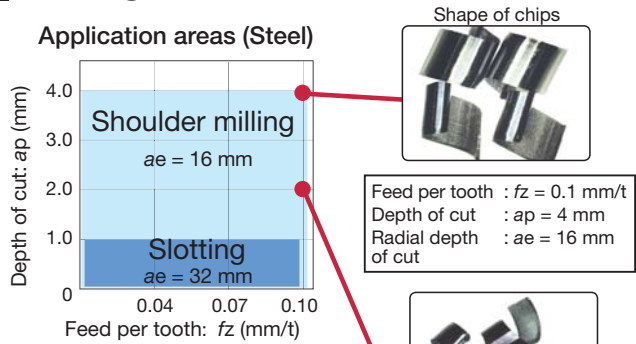

Work material : S55C
Insert : SDMT050204PN-MJ
Grade : AH725
Tool : TPD05R032M16.0E06
Cutting speed : $Vc = 180 \text{ m/min}$
Cutting fluid : Dry cutting

Feed per tooth : $fz = 0.1 \text{ mm/t}$
Depth of cut : $ap = 2 \text{ mm}$
Radial depth of cut : $ae = 16 \text{ mm}$

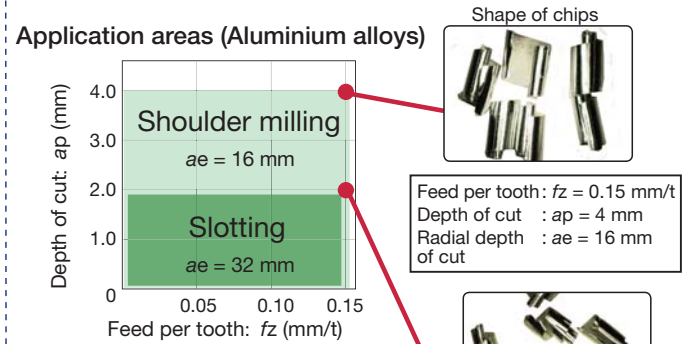

Work material : Aluminium alloys (7000 series)
Insert : SDHT050204FN-AJ
Grade : TH10
Tool : TPD05R032M16.0E06
Cutting speed : $Vc = 400 \text{ m/min}$
Cutting fluid : Dry cutting

Feed per tooth : $fz = 0.15 \text{ mm/t}$
Depth of cut : $ap = 2 \text{ mm}$
Radial depth of cut : $ae = 16 \text{ mm}$

Specification

Bore type

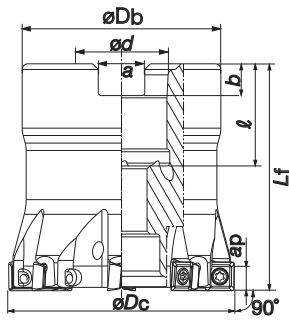

Shank type

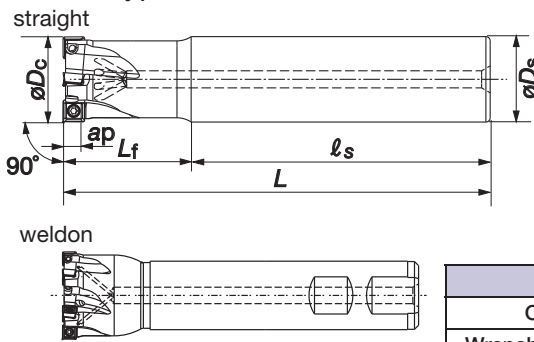

Insert

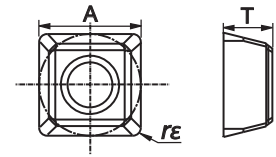

Max. ap = 4 mm

Descriptions	Parts Cat. No.
Clamping screw	CSPB-2L043
Wrench (Substitution Wrench)	IP-6DB (IP-6D)

Bore type

Cat. No.	Stock	No. of Inserts	Dimensions (mm)						Weight (kg)	Air hole	Cutter mounting screw	Inserts	
			ϕD_c	ϕD_b	ϕd	l	L_f	b					a
TPD05R032M16.0E06	●	6	32	30	16	20	32	5.6	8.4	0.1	with	CM8x30H	SDMT050204PN-MJ
TPD05R040M22.0E08	●	8	40	38	22	22	40	6.3	10.4	0.2	with	CM10x30H	SDHT050204FN-AJ

Shank type

Cat. No.	Stock	No. of Inserts	Dimensions (mm)					Weight (kg)	Air hole	Shank type	Inserts
			ϕD_c	ϕD_s	l_s	L_f	L				
EPD05R012M12.0-02	●	2	12	12	62	18	80	0.1	with	straight	SDMT050204PN-MJ SDHT050204FN-AJ
EPD05R016M16.0-03	●	3	16	16	90	20	110	0.2	with	straight	
EPD05R020M20.0W04	●	4	20	20	80	25	105	0.2	with	weldon	
EPD05R025M20.0W05	●	5	25	20	90	25	115	0.3	with	weldon	
EPD05R032M25.0W06	●	6	32	25	98	32	130	0.5	with	weldon	
EPD05R040M32.0W08	●	8	40	32	100	40	140	0.8	with	weldon	

Insert

Cat. No.	Accuracy	Honing	Stock			Dimensions (mm)			Cutter
			Coated grades		Carbide	A	T	$r\epsilon$	
			AH725	AH140	TH10				
SDMT050204PN-MJ	M	with	●	●		5.09	2.38	0.4	TPD05... EPD05...
SDHT050204FN-AJ	H	without			●	5.09	2.39	0.4	

Standard cutting conditions

Work material	Brinell hardness HB	Grades	Cutting Speed V_c (m/min)	Feed per tooth f_z (mm/t)
Low carbon steels (S15C, SS400 etc.)	~ 200	AH725	230 - 280 - 320	0.04 - 0.07 - 0.10
High carbon steels (S45C, S55C etc.)	200 ~ 300		150 - 180 - 230	
Alloyed steels (SCM440, SCr415 etc.)	150 ~ 300		110 - 120 - 130	
Tool steels (SK, SKH etc.)	~ 300	AH140	100 - 150 - 200	0.03 - 0.06 - 0.09
Stainless steels (SUS304, SUS316 etc.)	-	AH725	200 - 250 - 300	0.05 - 0.08 - 0.12
Grey cast irons (FC250, FC300 etc.)	150 ~ 250	TH10	350 - 400 - 500	0.05 - 0.10 - 0.15
Ductile cast irons (FCD400 etc.)			100 - 150 - 200	
Aluminium alloys (Si < 13%)	-	TH10	350 - 400 - 500	0.05 - 0.10 - 0.15
Aluminium alloys (Si ≥ 13%)	-		100 - 150 - 200	

*With large depth and width of cut, set the V_c and f_z to the lower bound side and check the vibration and spindle load of the machine.



Tungaloy Corporation

<http://www.tungaloy.co.jp/>

Distributed by:



ISO 9001 certified
QC00J0056
18/10/1996
Tungaloy Co.Ltd

ISO 14001 certified
EC97J1123
Japan site and Asian
production site
Tungaloy Group